

# Design of roots flow meter based on ARM Cortex M3

Akhil Kumar T V,  
 Lakshmi Pravallika N

Department of electronics and communication, M S  
 Engineering College, Bengaluru, India,  
 tridhara2010@gmail.com

Venkateshappa

Department of electronics and communication, M S  
 Engineering College, Bengaluru, India,  
 venkat\_harishith@rediffmail.com

**Abstract:** This paper introduces the roots flow meter based on ARM Cortex-M3 processor and  $\mu\text{C}/\text{OS-II}$  real time operating system. ARM Cortex-M3 is industry leading 32-bit processor with low power consumption and higher performance compared to 8-bit and 16-bit processors. Using  $\mu\text{C}/\text{OS}$  real time operating system, it will compensating temperature and pressure for roots flow meter. Its uses ZigBee technology for better communication and networking.

**Keywords:** ARM Cortex-M3;  $\mu\text{C}/\text{OS-II}$ ; roots flow; low power

## I. INTRODUCTION

Gas flow has always being difficult to measure accurately in industrial engineering. Since the working is complex and unstable, it is necessary to use the roots flow meter to compensate the temperature and pressure automatically in real time [1]. With the ARM Cortex-M3 processor and the  $\mu\text{C}/\text{OS-II}$  real time operating system the roots flow meter introduced here can meet the requirements of the gas flow meter and have such advantages like low power consumption, real-time, diagnosis, automatic compensation, etc.

## II. PRINCIPLES AND MATHEMATICAL MODEL OF ROOTS FLOW METER

### A. Working principle of ROOTS FLOW METER

The roots flow meter is one kind of waist wheel flow meters. There is a fixed large space internal and a group of revolvers (waist wheel) breaks the large space into several small spaces, which are known volumes. Waist wheel turns continuously at the effect of the different pressure of gas flow. Then the gas flow is expelled from the little space continuously. The speed of waist wheel is converted to corresponding frequency electrical impulses by the impuler. Pulse signal goes into the microcontroller measuring system after being magnified by the magnifier. Then throw the counts and accumulative counts of electrical impulses and temperature and pressure compensation, we can work out the instantaneous flow rate and integrated flow and display on the LCD screen.

### B. Temperature and pressure compensation

In general, the gas can be seen as ideal gas when its pressure is little but temperature is high. In gas flow measurement, the time that gas flows through a flow meter is very short, so there is no time for the gas to exchange heat with the world outside (The excite heat by friction is not considered in this condition), thus, the change processes of the state of gas can approximately be seen as Reversible adiabatic process or Isentropic procedure. So the state equation of adiabatic process can be used to compute specific volume or density under different state. However, in Engineering, the density is usually calculated based on the perfect gas equation Boyle Charles Equation ( $pV = nRT$ ), that is:

$$\rho = \rho_x \frac{p T_x}{p_x T}$$

$\rho$  = The density of gas under working state;

$\rho_x$  = The density of gas under standard conditions;

$P$  = The pressure of gas under working state;

$P_x$  = The pressure of gas under standard conditions;

$T$  = The temperature of gas under working state;

$T_x$  = The temperature of gas under standard conditions.

In order to illustrate the extent of differences between the working gas and ideal gas, we definite parameter  $Z$  as Coefficient of Compressibility to measure the extent of proximity between real gas and ideal gas:

$$Z = PV/nRT \quad (2)$$

The Coefficient of Compressibility of gas is ( $Z=1$ ) when it is ideal gas, that is,

$$\rho = \rho_x \frac{p T_x Z_x}{p_x T Z} \quad (3)$$

$Z_x$  = The Coefficient of Compressibility of gas under standard condition.

$Z$  = The Coefficient of Compressibility of gas under working state.

However, the state change of gas will not abide by the rules of state equation of ideal gas when the pressure and

temperature is high and the operation conditions changes a lot. Especially under high pressure and near the saturation curve, The Coefficient of Compressibility of working gas  $Z$  is not equal to the Coefficient of Compressibility of gas under standard condition  $Z_x$ . There upon; we can use Newton iteration method to calculate the Coefficient of Compressibility  $Z$  in the universal equation: Redlich Kwong.

$$Z^3 - Z^2 - (B^2 + B - A)Z - AB = 0$$

$$A = \frac{0.42748p_r}{T_r^{2.5}}$$

$$B = \frac{0.084457P_r}{T_r}$$

$$p_r = \frac{p}{p_c} \quad T_r = \frac{T}{T_c}$$

$P_r$  = Gas contrast pressure [2]

### III. HARDWARE DESIGN

The hardware components of roots flow meter includes EFM32G890F128 main controller, the pulse signal acquisition module, temperature and pressure acquisition module, LCD display module, keyboard, ZigBee and RS485 data transmission module. "Fig. 1" is a block diagram of system hardware.

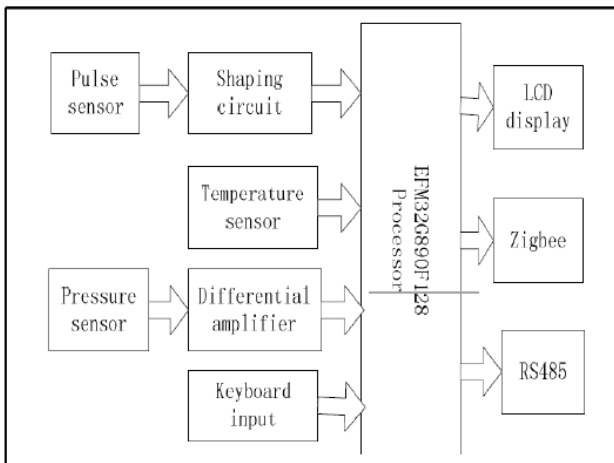

Fig 1. System hardware structure

#### A. Main Controller Module

Energy Micro Company makes EFM32G890F128 with ARM Cortex-M3 core inside. The micro-controller includes a LCD controller of running current below 900nA, 8 way 12-bit 1MSPS ADC of running current below 200uA, a power lost detection circuit detecting the running current weather below 100nA, a 32KHz real-time counter of running current 50nA, a 9600bps UART of running current 100nA. And it supports  $\mu$ C/OS-II real-time operating system.

#### B. Data Acquisition Module

Flow pulse signal is detected by wiegang sensor. The principle is that the wiegang sensor's bi-stable function alloy material's magnetizing direction turn over instantly

under the excitation of external alternating magnetic field. When the external magnetic leaves, the magnetizing direction return to the original direction. This kind of sensor's feature is that without using plus power (zero power pulse), without a mechanical contact, no vibration influence, and is very suitable for micro-consumption electronic instrument. "Fig. 2" is a circuit diagram of pulse acquisition by wiegang sensor.

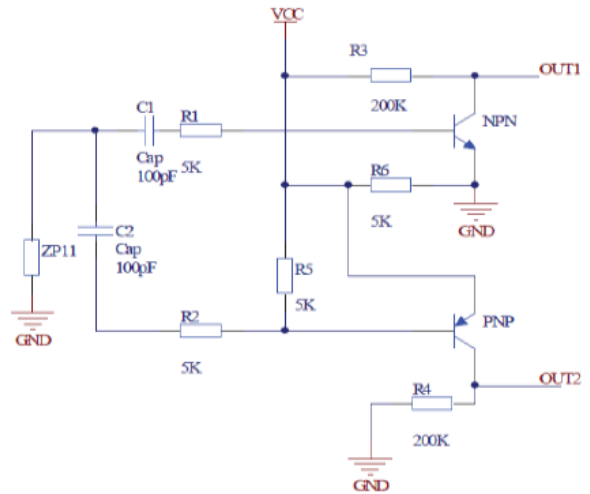

Fig 2. Pulse acquisition circuit

Temperature sensor collects the temperature signal by using a single bus digital sensor called DS18B20. Based on DS18B20 the temperature measurement system has such advantages as simplicity, high precision, connecting convenience, occupying less pins, etc [4]. Circuit diagram of temperature gathering is shown in "Fig. 3".

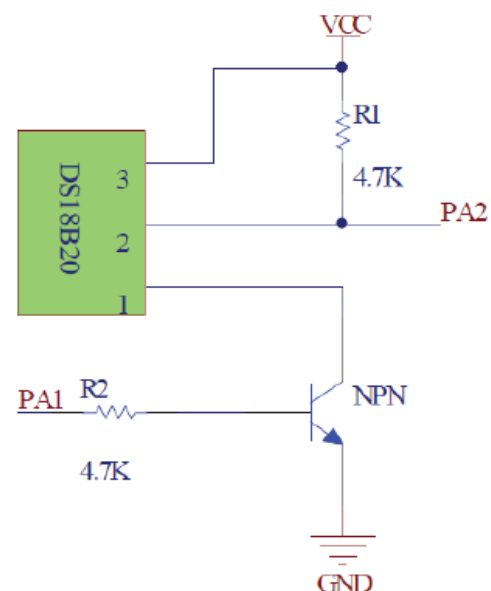

Fig 3. Temperature gathering

Pressure sensor select MC series pressure sensor and it needs persistence current source to supply power. This

system chooses persistence current source control chip LM334. When pressure sensor collects pressure signal, LM334 works to supply about 1 mA current for it. Then pressure sensor can detect pressure accurately and converse it to electrical signal. "Fig. 4" is a circuit diagram of pressure acquisition and amplification.

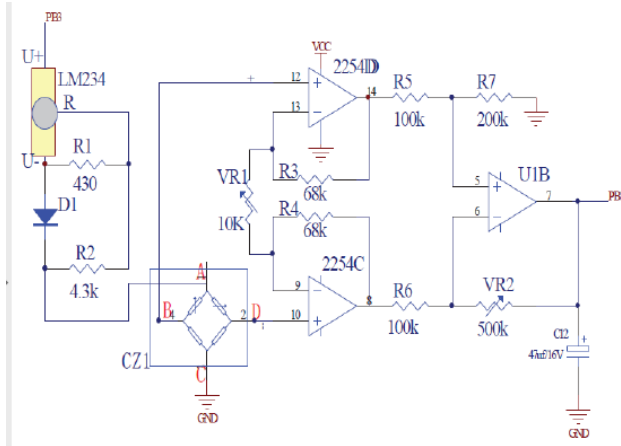

Fig 4. Pressure acquisition and amplification

### C. LCD Display and Keypad Module

Keyboard has four keys and each of them is independent and has no interference. When one key is pressed, MCU will handle it accordingly. Display module is used to display measurement data and system settings, such as temperature, pressure, instantaneous flow, cumulative flow, battery and other information. Keys are used to set the flow meter's parameters, flow upper limit, and clear cumulated flow amount manually.

### D. ZigBee and RS485 Data Transmission Module

ZigBee is suitable for short, low rate of wireless network technology. It has low power consumption, high efficiency of communication advantages. System uses the CC2430 chip, which is made by Chipcon Company. The CC2430 chip accords with 2.4 GHz radio frequency of ZigBee technology, including ZigBee RF, memory and micro controller. Therefore, the CC2430 chip has such advantages as low power consumption, high reliability, delay short, etc.[3]

RS-485, half-duplex communication, with maximum transmission distance for 120 km is very suitable for long distance communication. So it can be used in some industrial fields' condition of no ZigBee.

## IV. SOFTWARE DESIGN

During the design of the software platform, adopting the embedded real-time operating system to schedule and manage the task of system can meet the requirements about real-time and expansibility. In addition, by using µC/OS-II real-time operating system kernel, it makes application system design simple and the whole system structure easily to be operated [4].

### A. Main Function

The main function mainly realizes the initialization of system hardware and operating system. The hardware initialization includes interruption, keyboard, display, etc. The initialization of operating system includes task control block and event control block. Before startup to schedule multi tasks, the operating system must create a startup task at least, which mainly responsible for the initialization and start-up of clock, interruption startup, the initialization of communications tasks module, and tasks division, etc. Main program flowchart is illustrated in "Fig. 5".

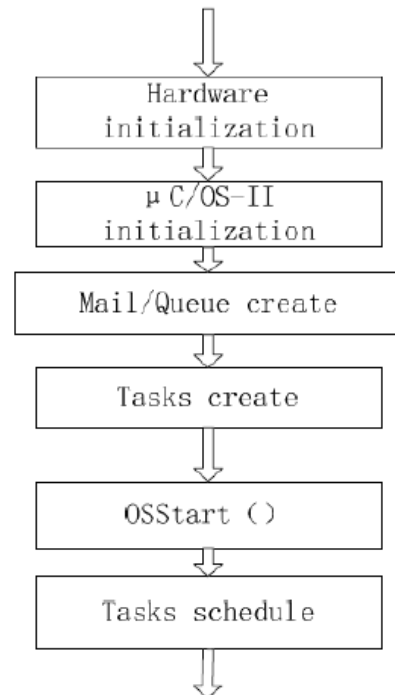

Fig 5. Main program flowchart

### B. Task Division

To realize the real-time multitasking about all sorts of functions, it is necessary to divide the tasks. According to the importance and the real-time property of tasks, the tasks are divided into 9 different priorities as follows.

- 1) The first priority: Pulse signal collection.
- 2) The second priority: Temperature signal collection.
- 3) The third priority: Pressure signal collection.
- 4) The fourth priority: Data processing.
- 5) The fifth priority: ZigBee communication.
- 6) The sixth priority: RS485 communication.
- 7) The seventh priority: LCD display.
- 8) The eighth priority: Keyboard input.
- 9) The ninth priority: System monitoring.

### C. Synchronization and Scheduling of Tasks

Tasks' functions of the multi-tasking operating system are often different from general function, because they are an infinite loop and have no return values. If there is no higher priority task in a ready state, current task will not give up the right of use CPU. In order to realize operating system synchronization of failure-free operation and events concerning, flags of different tasks communication and events must be treated properly. The structure of all tasks of system is as shown in "Fig. 6".

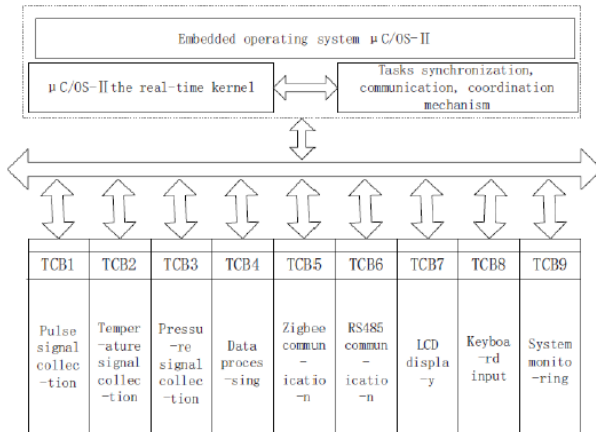

Fig 6. System tasks structure

## V. CONCLUSION

The roots flow meter of this paper introduces in a low cost, low power and real time spirit, is based on ARM Cortex-M3 hardware platform and μC/OS-II operating system. It effectively solves the real time problems in the aspect of pressure and temperature compensation during the process of flow meter working. Both ZigBee technology and RS485 data transmission are applied to ensure the communication between flow meter with the host computer real time and accuracy. At the same time, software system is former and more reliable because of the multi-tasking real time operating system.

## REFERENCES

- [1] Juliusz Topolnicki, Mateusz Kudasik, Norbert Skoczylas, Jacek Sobczyk, "Low cost capillary flow meter", Sensors and Actuators A: Physical, Volume 152, Issue 2, 18 June 2009, pp. 146-150.
- [2] Tong Zheng, Yinping Jiang, Yanwen Li, etc. "Based on ultra-low power MSP430 Roots Flow Totalizer Development", Computer Measurement and Control, 2006.14(4), pp. 516-517.
- [3] Wen-Tsai Sung, Yao-Chi Hsu, "Designing an industrial real-time measurement and monitoring system based on embedded system and ZigBee", Expert Systems with Applications, Volume 38, Issue 4, April 2011, pp. 4522-4529.
- [4] Jean J. Labrosse, MicroC/OS-II The real-time kernel, Beijing university of aeronautics and astronautics press, 2003.