

# Smart Army Jacket

Bhuvaneshwari, Nipun Pradeep,  
Pavan Kumar, Sowmya  
UG Students, Department of EC, Brindavan  
College of Engineering, Bangalore

Harish K  
Professor, Department of EC, Brindavan College of  
Engineering, Bangalore

**Abstract:** *Wearable technologies are now pervading many applications in several fields. The aim of this review paper is to collect and summarize the actual smart clothing in the space and military field where conditions could be critical for health and safety, and outline the innovation trend for innovative services to police and soldiers. The aim of this paper is to consider data input methods and technologies related to information input into electronic systems that would be suitable for smart garments. An overview of recent developments in the area of flexible switches is provided, describing processes used to fabricate these connections and highlighting issues and problems associated with it.*

**Keywords:** *Flexible switches; Smart garments; Wearable technologies.*

## I. INTRODUCTION

The soldier of the future is most likely going to be the protagonist in the practical application of wearable technology. In fact, the first idea to put embedded sensors into garments was given birth in the military field thanks to Dr. Sundaresan Jayaraman, researcher team at Georgia Institute of Technology. The wearable T-shirt won the best invention of the Millennium and TIME named it as one of the best inventions in 2001.

Today wearable technologies are evolving not only in sensorized garments but also integrated in small body accessories (bracelets, necklaces, rings).

In this paper we will focus only on sensorized garments applied to space and military applications. At the moment the Experience is very limited. We can recapitulate the goals of these applications in the following points:

- Health monitoring
- Environmental Safety monitoring
- Stress management
- Empowering human functions

Smart clothing is linked to the information and communication infrastructures and provides quiet service to humans by perceiving the environment and at the same time by providing the information generated in personal areas such as health, emotions, and locations of person to the environment. To carry out these functions, all the

information systems are equipped with input and output functions [1].

Sensors or switches are used for input in smart clothing; they determine conditions of the surrounding environment (for example, temperature or humidity sensor) or operate and control the system (for example, system ON/OFF switch, volume control buttons). To keep wearing feeling as satisfactory as possible, it is preferable to replace data input mechanical buttons with flexible switches and connections. The aim of this paper is to consider data input methods and technologies related to information input into system that would be suitable for smart garments. As a result of this study, a prototype of input interface is developed.

The main aim of the smart army jacket is to provide safety for soldier like tracking the location of soldier and environment around the soldier.

## II. LITERATURE SURVEY

Indian companies focusing on smart textiles:

Table 1. Literature Survey

Sl.No	Company	Brief Description
1	Ducere Technologies	Started in 2011 and a pioneer in wearable technologies. The foot brand "lechal" is one of their innovations.
2	Lumos Design Technologies	New startup in wearable technology building energy harnessing techniques into objects like bag packs and jackets.
3	Broadcast Wear	New startup innovator in the field of smart apparel.

The Department of Textile Technology at the Indian Institute of Technology (IIT), Delhi has recognized smart textiles as a significant area for research and development and is playing an active role as one of the pioneers in this field. The Department has established a research group on Smart and Innovative Textile Materials (SMITA).

The main objectives of the group are:

- To create a national facility for research and technology development in the area of smart textiles based on innovative materials such as nanoparticles, nanofibers, Nano surface engineering, phase change materials and stimuli sensitive polymers.

- To bring together expertise from academia and industry to facilitate development of new technologies/products in the upcoming area of smart textiles.
- To create trained manpower that can assist industry in further research, product development and production of smart textiles based on new technologies.

SMITA group has significant funding from both government and Indian industry. It receives support from Department of Science and Technology (DST), Defense Research and Development Organization (DRDO), Council of Scientific and Industrial Research (CSIR) and Ministry of Human Resource Development (MHRD). Some of the recent industry partners include Resil Chemicals Pvt. Ltd., Pluss Polymers, Mahle Filter Systems (India) Ltd., SRF Ltd., Reliance Industries Ltd., Sterilite Optical Technologies Ltd., Aditya Birla Management Corporation Ltd., Thai Acrylic Ltd., Century Enka.

Several unconventional examples of flexible switching and connections designed from textile materials or clothing furniture are described. Available soft button / keypad products are considered and other methods and types of keypads are analyzed. Some flexible circuit substrates for textile platform construction are described – embroidery, printing, weaving, knitting, coating, sewing, gluing.[1-128]. In Fig.1 a) Flexible circuit made of conductive fabric stuck on elastic non-conductive surface is shown. b) A keypad is shown that was embroidered with conductive threads on denim and was used in MIT Media Lab project ‘Musical Jacket’. In c) To prevent possible short circuits in between wires threads are generally coated with insulating material. d) Printed circuit pattern is shown. Narrow knitted band is shown. e) Tin coated fabric is shown. f) Copper coated fabric is shown.[2,3]

Flexible keypads can be integrated in the majority of smart clothing and accessories where data input and/or control is necessary from wearer’s side. Examples are MP3 clothing, iPod jackets, GPS jacket, Message bag etc. Control interfaces should be close to the parts of body concerned, for example in MP3 jacket earphones are located in a collar or a bonnet, a microphone is in a collar and a keyboard is applied to the sleeve of a jacket. Some variants of keypad arrangements are shown in Fig.3. The ergonomic adaptation of all these control interfaces to clothing is also very important. In contrast to certain miniaturized communication devices, clothing has a greater surface area, which enables it to offer more functionality. For example, the small keyboard of a mobile phone becomes much more readable when transposed to the surface of a piece of clothing that is three times larger [4]

The global smart textiles market was around US\$ 580 million in 2015. Smart textiles can be split on the basis of their end use industry namely, fashion & entertainment, sports & fitness, medical, transportation, protection & military and architecture. Further focus is needed in

research & development and foreign investment in the sector to boost this sector in India. Overall technical textiles and smart textile market has bright future in India. Overall consumption in India is expected to grow and the growth of various end use industries offers good potential for the technical textiles industry. India also offers many benefits for manufacturing of technical textiles including availability of raw materials, competitive labour cost, modern production facilities etc.

### III. BLOCK DIAGRAM

This work involves the design, fabrication, and testing of a smart and intelligent soldier jacket that has integrated interconnects, antennas, sensors for monitoring both the physiological characteristics of the soldier wearing the jacket and the environment around the soldier as well as devices for signal processing and communication.

Textile-based flexible circuit boards and multi-chip modules will be developed in the initial stage. Next, modelling, fabrication and testing of different types of radio frequency and microwave antennas on textile-based and polymeric substrates will take place.

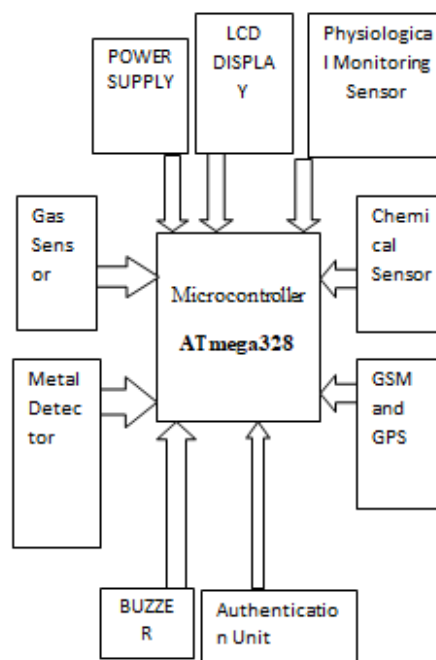

Fig 1. Block Diagram of Smart Army Jacket

Finally, several kinds of sensors will be developed and integrated into the textiles. Features like signal processing chip, chemical sensor and communication chip will help the soldiers in mobility, threat detection and communication.

#### A. Hardware Requirement:

ATmega328P Microcontroller, PIR Sensor, Gas Sensor, Temperature Sensor, Buzzer, Metal Detector, LED Lights, Bio-metric Module, Connecting wires, Soldering Gun, 12V Battery, Registers, Capacitors, Soldier Jacket etc.

### B. Software Requirement:

Keil  $\mu$ Vision IDE, debuggers, simulators, integrated environments, evaluation boards. Programming Language: Embedded C.

## IV. CONNECTIONS

In this work, firstly textile-based flexible circuit boards and multi-chip modules will be developed. Secondly, we will carry out the modeling, fabrication, and testing of different kinds of RF and microwave antennas on textile-based and polymeric substrates. Finally, we will be developing and integrating several kinds of physiological monitoring sensors as well as environment sensors on textile fabrics. A schematic of Smart and Intelligent Soldier Jacket is shown below:

## V. APPLICATIONS AND ISSUES

Applications like:

- Military Sector
- Indian Navy
- Automobiles Industry
- Healthcare Industry
- Fitness & Sports Industry
- Fashion & Entertainment Industry
- Aviation Industry

Wearable Jackets must be:

- Comfortably worn on the body for extended periods of time
- Independently long powered (Power backup) and use cost effective sensors or microcomputers to process information.

## VI. CONCLUSION

In the future, combat soldiers can be dressed in high-tech uniforms, fitted with everything, from navigation and water purifying systems to climate control. More than a decade will pass before super suits make the combat soldiers stronger, smarter.

The main aim is to increase the protection and survivability of the combat soldiers. The nano-materials and smart structures can also provide the future soldiers with super strength, protection against bio-weapons, and even a way to communicate covertly. Another goal is to help soldiers to do everything they need to do with smaller equipment and a lighter load. If electronics and optical technologies could be integrated successfully into the textiles, there could be a striking improvement in the battlefield communications.

The future warrior systems include global positioning systems, combat identification sensors, monitors, chemical detectors, and electronically controlled weapons, all connected to the soldier's computer to provide him instant access to information. But getting the

wire, and more futuristic technologies such as optics, into the uniforms and smart vests, and making these easy to use, is challenging. Wires must be flexible enough to be comfortable, carry signals, be safe to the soldier, and not give away his or her position.

In the future, by the development of the high-tech textiles, the battle dress uniform can be hardened into an instant shield with the push of a button; also there can be chameleon-like battle suits that can change their colour depending on the surroundings. If a combat soldier is hit in the leg, sensors relay information about his injury and location to the field headquarters. Sensors inform the field headquarters about the soldier who is the closest to the wounded soldier; new orders and the target's position appear on the rescuer's head-up display.

The materials of the new era will benefit the soldiers in the following ways:

- Lightweight, high-durability fabrics: Uniform, packs
- Lightweight materials: Rock-frame, bayonet, rifle, ammo, tools
- Reduced weight ballistic protection: Small arm plates, fragmentation vest
- Laser eye protection
- Next generation displays: Ultra thin high-resolution displays
- Information processing and storage: Small, massive durable storage devices, distributed microprocessors, conductor fibres embedded in the fabric
- Artificial muscles: Actuator for increased human performance.
- Power storage/energy generation: Harvest energy from fabric flexure, hydrogen storage, embedded flexible batteries
- Drug and nutrient delivery on demand.

## REFERENCES

- [1] Gilsoo Cho. Smart Clothing. Technology and applications. Taylor and Francis Group and CRC Press LLC, 2010, pp 90 91-92 97 95 95
- [2] C.A. Winterhalter, J. Teverovsky, W. Horowitz, V. Sharma, K. Lee. Wearable ElectroTextiles For Battlefield Awareness. ADM001736, Proceedings for the Army Science Conference (24th), Orlando, Florida, 2005.
- [3] J. Cho, J.Moon, M.Sung, K.Jeong, G.Cho. Design and evaluation of textile based signal transmission lines and keypads for smart wear. Human-Computer Interaction. Interaction Platforms and Techniques. Lecture Notes in Computer Science, 2007, Volume 4551/2007.
- [4] Langereis, G.R.; Bouwstra, S.; Chen, W. Sensors, Actuators and Computing Architecture Systems for Smart Textiles. In Smart Textiles for Protection; Chapman, R., Ed.; Woodhead Publishing: Cambridge, UK, 2012; Volume 1, pp. 190–213.
- [5] Custodio, V.; Herrera, F.J.; López, G.; Moreno, J.I. A review on architectures and communications technologies for wearable health-monitoring systems. Sensors 2012, 12, 13907–13946.

- [6] Coosemans, J.; Hermans, B.; Puers, R. Integrating wireless ECG monitoring in textiles. *Sens. Actuators A Phys.* 2006, 130–131, 48–53.
- [7] Linz, T.; Gourmelon, L.; Langereis, G. Contactless EMG sensors embroidered onto textile. In *Proceedings of the 4th International Workshop on Wearable and Implantable Body Sensor Networks, Aachen, Germany, 26–28 March 2007; Volume 13, pp. 29–34.*
- [8] Löhede, J.; Seoane, F.; Thordstein, M. Soft textile electrodes for EEG monitoring. In *Proceedings of 2010 the 10th IEEE International Conference on Information Technology and Applications in Biomedicine (ITAB), Corfu, Greece, 2–5 November 2010; pp. 1–4.*
- [9] Löhede, J.; Seoane, F.; Thordstein, M. Textile electrodes for EEG recording—A pilot study. *Sensors* 2012, 12, 16907–16919.
- [10] Sibinski, M.; Jakubowska, M.; Sloma, M. Flexible temperature sensors on fibers. *Sensors* 2010, 10, 7934–7946.